

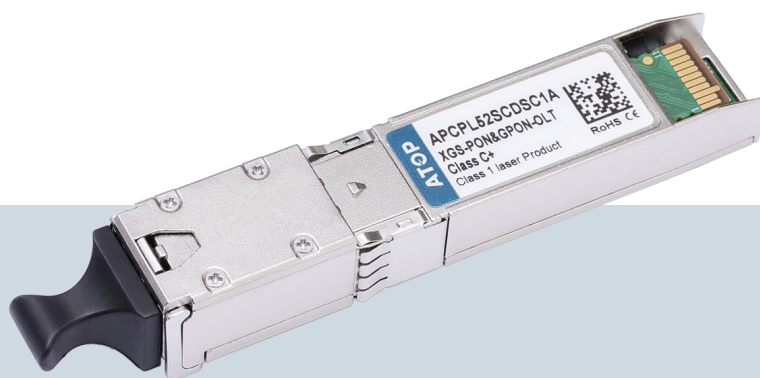

# SFP+ 9.953G&2.488(Down)/9.953G/2.488G &1.244G(Up) XGS-PON&GPON OLT Class C+ 20km Optical Transceiver

APCPL52SCDSC1A



# SFP+ 9.953G&2.488G(Down)/9.953G/2.488G &1.244G(Up) XGS-PON&GPON OLT Class C+ 20km Optical Transceiver

## APCPL52SCDSC1A

ATOP's APCPL52SCDSC1A is a combination of XGS-PON OLT and GPON OLT optical transceiver in a SFP+ housing, and it is compliant to ITU-T G.9807.1 XGS-PON and ITU-T G.984.2 GPON standard. This module can support XGS-PON and GPON over a single fiber via coarse wave division multiplexing. XGS-PON feature supports 9.953 Gbps continuous-mode transmission by 1577 nm EML laser and 9.953/2.488 Gbps burst-mode reception by 1270 nm APD/TIA. GPON feature supports 2.488 Gbps continuous-mode transmission by 1490nm DFB laser and 1.244 Gbps burst-mode reception by 1310nm APD/TIA.

It has been designed to meet the harshest external operating conditions that include temperature, humidity and EMI interference. The module offers very high functionality and feature integration, accessible via a two-wire serial interface.

### Product Features

- ✓ Single-fiber bi-directional transmission
- ✓ SFP+ Package
- ✓ 2x11 SFP+ Electrical interface
- ✓ Hot pluggable
- ✓ Typical power consumption 2.5W
- ✓ SC receptacle optical connector
- ✓ Operating case temperature: 0 to 70 °C
- ✓ 3.3V power supply
- ✓ ODN Class C+
- ✓ RoHS 2 compliant
- ✓ ITU-T G. 987.2 compliant
- ✓ ITU-T G. 9807.1 compliant
- ✓ ITU-T G.984.2 compliant

### Applications

- ✓ Gigabits Access networks
- ✓ FTTH
- ✓ FTTC
- ✓ FTTB
- ✓ XGS-PON and GPON Combo access networks

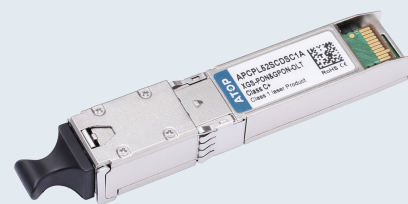

## Product Selection

Part Number	Operating temperature	DDMI
APCPL52SCDSC1A	Commercial	Yes

## Pin Descriptions

Pin	Symbol	Name	Ref.
1	GPON TD+	Transmit Data Input	Note1
2	GPON TD-	Inv. Transmit Data Input	Note1
3	GND	Ground	Ground
4	TX Disable	Transmitter Disable	Note2
5	SDA	2 wire serial ID interface, SDA	Note3
6	SCL	2 wire serial ID interface, SCL	Note3
7	GPON RD-	GPON Inv. Received Data Output	Note4
8	XGS-PON Reset	Reset for XGS-PON receiver	
9	XGS-PON SD	Signal Detect	
10	RSSI Trig	RSSI Trigger input	Note5
11	GPON RD+	GPON Received Data Output	Note6
12	Rate_Sel	Rate select Control input	H-9.953G; L-2.488G
13	GND	Ground	
14	XGS-PON RD-	Inv. Received Data Output	CML, DC-coupling in module, coupling capacitor on board.
15	XGS-PON RD+	Received Data Output	CML, DC-coupling in module, coupling capacitor on board.
16	GPON SD	GPON RX Signal Detect	
17	VccR	Receiver Power	3.3V± 5%
18	VccT	Transmitter Power	3.3V± 5%
19	GPON Reset	Reset for GPON Receiver	
20	XGS-PON TD+	Transmit Data Input	AC-coupled, differential lines with 100Ω differential termination inside the module
21	XGS-PON TD-	Inv. Transmit Data Input	AC-coupled, differential lines with 100Ω differential termination inside the module
22	GND	Ground	

### Note

1. AC-coupled, differential lines with 100Ω differential termination inside the module.
2. TX disable control both XGS-PON and GPON transmitter, and can be separately disable GPON or XGPON by IIC programming.
3. Should be pulled up with a 4.7 K~10 Kohm resistor to VCC on the host board.
4. LVPECL, DC-coupling in module, pull down offset resistor and coupling capacitor on board.
5. RSSI trigger control both XGS-PON and GPON receiver, and select GPON or XGS-PON channel by IIC programming. For register setting, see A2 byte 110, bit 3.
6. LVPECL, DC-coupling in module, pull down offset resistor and coupling capacitor on board.

## Pin-out Connector Block on Host Board

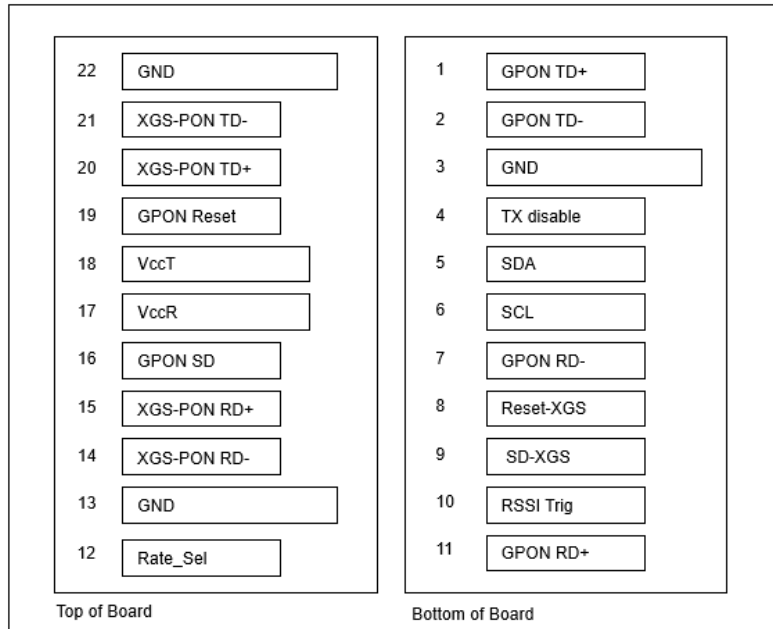

Pin-out of Connector Block on Host Board

## Transceiver Block Diagram

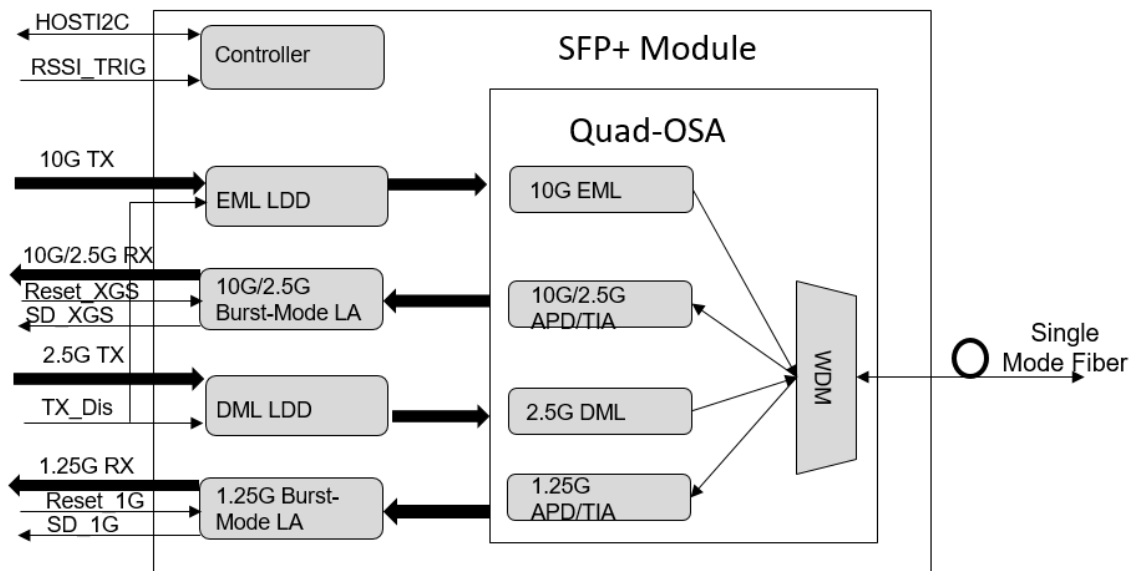

## Absolute Maximum Ratings

It has to be noted that the operation in excess of any individual absolute maximum ratings might cause permanent damage to this module.

Parameter	Symbol	Min	Typ	Max	Unit	Ref.
Maximum Supply Voltage	Vcc		3.3	3.6	V	
Maximum Input Voltage	Vin	0		3.6	V	
Storage temperature	Ts	-40		85	°C	
Relative humidity	RH	0		85	% Non-condensing	
Max Input power	Pmax	-3			dBm	

## Operating Environments

Electrical and optical characteristics below are defined under this operating environment, unless otherwise specified.

Parameter	Symbol	Min	Typ	Max	Unit	Ref.
Supply voltage	Vcc	3.135	3.3	3.465	V	
Case temperature	Top	0		70	°C	
Data Rate			TX:9.953& 2.488 RX: 9.953/2.488&1.244		Gbps	
ODN Class			C+			
Link distance with G.652		0.002		20	km	

## Electrical Characteristics

Parameter	Symbol	Min	Typ	Max	Unit	Ref.
Power dissipation	P		2.5	-	W	
Supply current	Icc		-	0.91	A	Steady state
Maximum Peak Current	Ipc		-	1.1	A	
Input differential impedance	Z <sub>IN</sub>	80	100	120	Ω	
Differential data input swing(XGS-PON input)	V <sub>IN</sub>	120	-	820	mV	AC Couple
Differential data input swing(GPON input)		200	-	1600	mV	
Differential data output swing(XGS-PON output)	V <sub>OUT</sub>	340	600	850	mV	CML
Differential data output swing(GPON output)		600	900	1600	mV	LVPECL
Tx Disable input Voltage	V <sub>IL</sub>	0		0.8	V	
	V <sub>IH</sub>	2		3.3	V	
SD output voltage	Fault	0	-	0.4	V	
	Normal	2	-	3.3	V	

## Optical Characteristics

Parameter	Symbol	Min	Typ	Max	Unit	Ref.
<b>Transmitter(GPON)</b>						
Laser type			DFB			
Nominal bit rate			2.48832		Gbps	
Output average power(EOL)		+3		+7	dBm	
Center wavelength		1480	1490	1500	nm	
Spectral width (-20 dB width)		-		1.0	nm	
Extinction ratio		8.2			dB	
Eye Mask Margin (1000 consecutive snapshots at typical rate and room temperature)			10% (ITU-T G.984.2 compliant)		%	
Side-Mode Suppression Ratio		30			dB	
Optical Power at Tx_disable				-39	dBm	
<b>Transmitter(XGS-PON)</b>						
Laser type			EML			
Nominal bit rate			9.95328		Gbps	
Output average power(EOL)		+5		+9	dBm	
Center wavelength		1575	1577	1580	nm	
Spectral width (-20 dB width)		-		1.0	nm	
Extinction ratio		8.2			dB	
Eye Mask Margin (1000 consecutive snapshots at typical rate and room temperature)			5% (ITU-T G.987.2 compliant)		%	
Side-Mode Suppression Ratio		30			dB	
Optical Power at Tx_disable				-39	dBm	

Parameter	Symbol	Min	Typ	Max	Unit	Ref.
<b>Receiver(GPON)</b>						
Receive wavelengths		1290	1310	1330	nm	
Sensitivity @Condition (BER=1*10 <sup>-4</sup> , 1.244Gbps, PRBS 2 <sup>23</sup> -1, NRZ)				-32	dBm	
Saturation power (Full temperature, EOL)		-12			dBm	
Max input power		-3			dBm	
SDA				-33	dBm	
SDD		-45			dBm	
Receiver reflectance				-20	dB	
Optical Return Loss tolerance		10			dB	
<b>Receiver(XGS-PON)</b>						
Receive wavelengths		1260	1270	1280	nm	
Sensitivity @Condition (BER=1*10 <sup>-3</sup> , 2.488Gbps, PRBS 2 <sup>23</sup> -1, NRZ)				-30.5	dBm	
Saturation power(2.488Gbps, Full temperature, EOL)		-10			dBm	
Sensitivity @Condition (BER=1*10 <sup>-3</sup> , 9.953Gbps, PRBS 2 <sup>31</sup> -1, NRZ)				-29	dBm	
Saturation power(9.953Gbps, Full temperature, EOL)		-9			dBm	
Max Input power		-3			dBm	
SDA@ 9.953Gbps				-30	dBm	
SDA@2.488Gbps				-31.5	dBm	
SDD		-45			dBm	
Receiver reflectance				-20	dB	
Optical Return Loss tolerance		10			dB	

## Mechanical Specifications

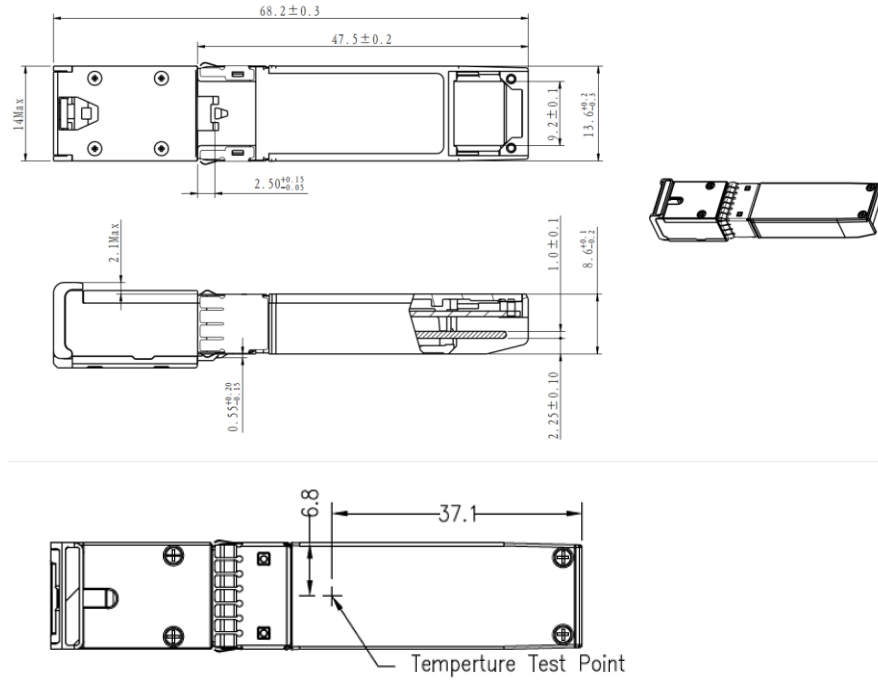

APCL52SCDSC1A

## RSSI timing requirement

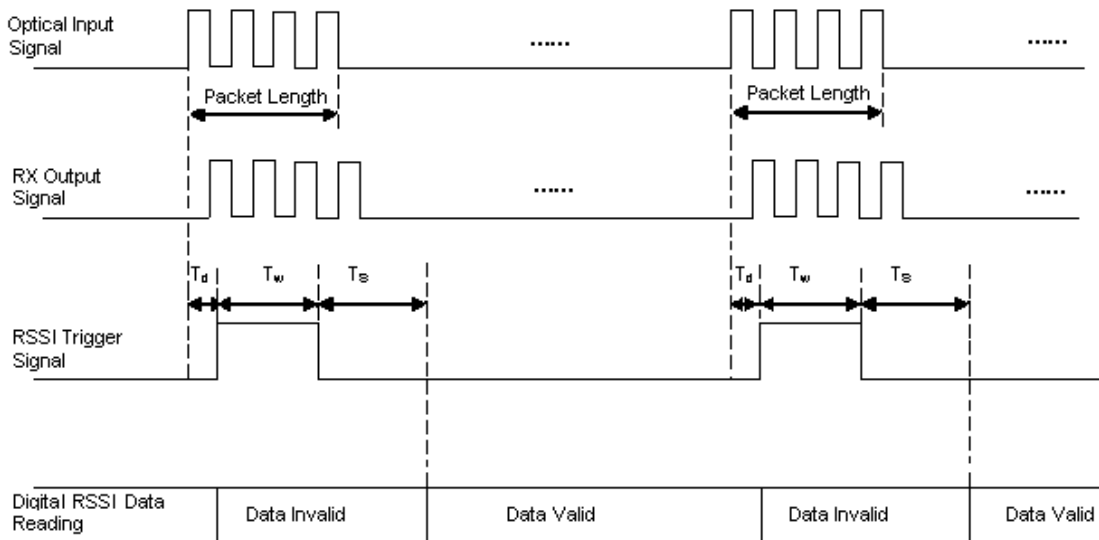



Parameter	Symbol	Min	Typ	Max	Unit	Ref.
Trigger delay	Td	1600			ns	
Trigger width	Tw	600		800	ns	
I2C read time	TI2C	500			us	

### SD timing requirement

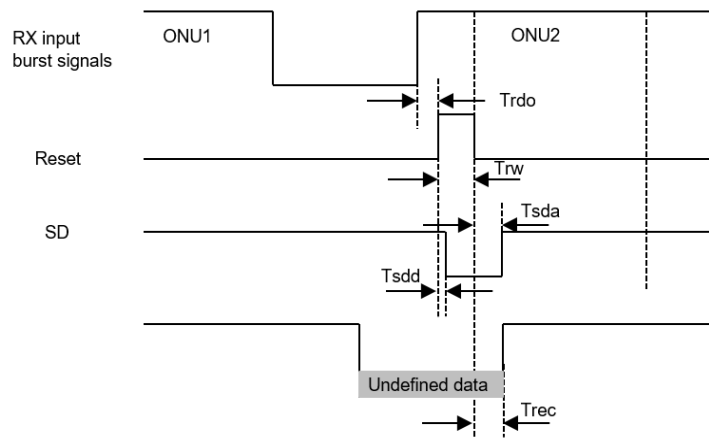

Parameter	Symbol	Min	Typ	Max	Unit	Ref.
GPON SD assert time	Tsda1			50	ns	
GPON SD de-assert time	Tsdd1		12.8	25.6	ns	
XGS-PON SD Assert Time	Tsda2			50	ns	
XGS-PON SD De-assert Time	Tsdd2		12.8	25.6	ns	
Data Recovery Time	Trec		25.6	50	ns	
Reset Width	Trw	25.6			ns	
Reset Delay Time during Operating	Trdo	0			ns	

### Rate\_Sel timing requirement

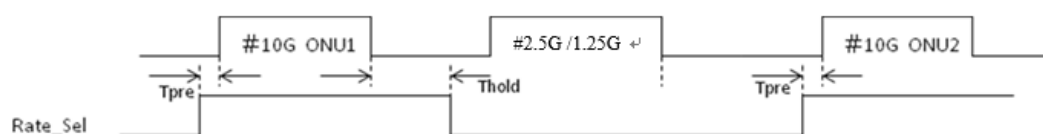

Parameter	Symbol	Min	Typ	Max	Unit	Ref.
Rate_Sel Preset Time	Tpre	12.8			ns	
Rate_Sel Hold Time	Thold	12.8			ns	

## Electrical Interface

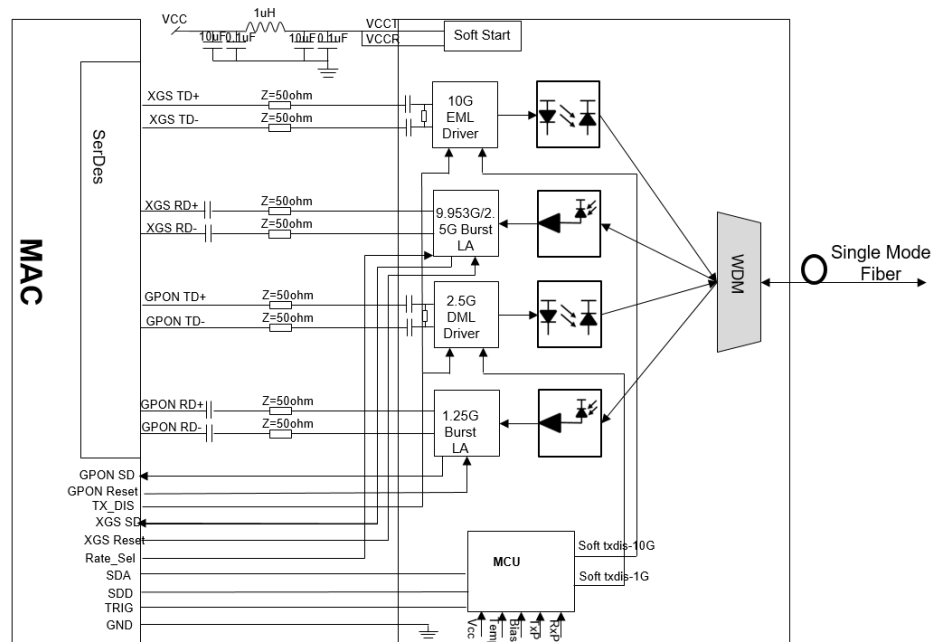

## Timing requirement of control and status I/O

Parameter	Symbol	Min	Typ	Max	Unit	Ref.
TX Disable Assert Time	t_off			100	µs	
TX Disable Negate Time	t_on			2	ms	
Time to initialize	t_init			300	ms	

## EEPROM Definitions

XGSPON Digital Diagnostic Memory Map

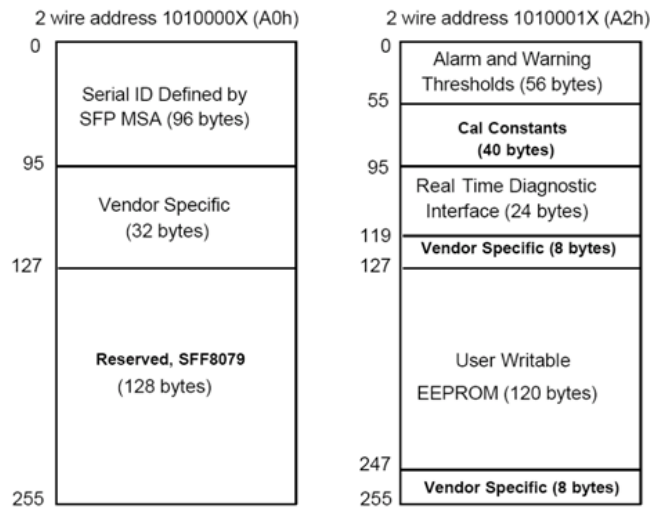

GPON Digital Diagnostic Memory Map

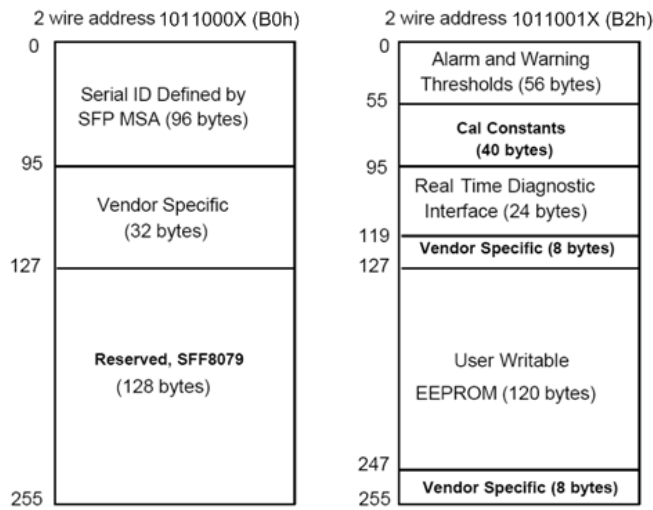

## Digital Diagnostic Monitoring Functions

APCPL52SCDSC1A supports the I2C-based diagnostic monitoring interface (DMI) defined in document SFF-8472. The host can access real-time performance of the transmitter and receiver optical power, temperature, supply voltage and bias current.

Parameter	Related Bytes (A2[00] Memory)	Accuracy	Ref.
<b>XGS-PON</b>			
Temperature	A2[00]: 96-97	±3°C	Floating/256 Note 1,2
Vcc Voltage	A2[00]: 98-99	<3%	Unit 1mV Note 2
Bias Current	A2[00]: 100-101	<10%	Unit 4uA Note 2
TX Power	A2[00]: 102-103	<3dB	Unit 0.2uW Note 2
RX Power	A2[00]: 104-105	<3dB	Unit 0.1uW Note 2,3
<b>GPON</b>			
Temperature	Refer to A2[00]: 96-97	±3°C	Floating/256 Note 1,2
Vcc Voltage	Refer to A2[00]: 98-99	<3%	Unit 1mV Note 2
Bias Current	B2[00]: 100-101	<10%	Unit 4uA Note 2
TX Power	B2[00]: 102-103	<3dB	Unit 0.2uW Note 2
RX Power	B2[00]: 104-105	<3dB	Unit 0.1uW Note 2,3

### Note

1. An actual temperature test point is fixed on the module case around the laser array.
2. Full operating temperature range.
3. RSSI DDM working range is between -12 to -32dBm.



let's make it personal

[atoptechnology.com](https://atoptechnology.com)