



1.25Gb/s CSFP BIDI Transceiver

APCS34123xxL20



1.25Gb/s CSFP BIDI Transceiver

APCS34123xxL20

Product Features

- ✓ Two Bi-Directional transceivers in one SFP package
- ✓ Up to 1.25Gb/s data links
- ✓ Duplex LC connector
- ✓ Hot-pluggable SFP footprint
- ✓ 1310nm FP laser transmitter
- ✓ RoHS compliant and Lead Free
- ✓ Up to 20km on 9/125um SMF
- ✓ Metal enclosure for lower EMI
- ✓ Single +3.3V power supply
- ✓ Compliant with CSFP MSA 2.0 (Option 2)
- ✓ Commercial and industrial operating temperature optional
- ✓ SFP MSA SFF-8074i Compliant

Applications

- ✓ Gigabit Ethernet
- ✓ Fibre Channel



Product Selection

Part Number	Operating temperature	DDMI
APCS34123CDL20	Commercial	Yes
APCS34123IDL20	Industrial	Yes

Regulatory Compliance

- ESD to the Electrical PINs: compatible with MIL-STD-883 Method 3015
- ESD to the Duplex LC Receptacle: compatible with EN 61000-4-2
- Immunity compatible with EN 61000-4-3
- EMI compatible with FCC Part 15 Class B
- Laser Eye Safety compatible with FDA 21CFR 1040.10 and 1040.11 IEC 60950, IEC60825-1,2
- RoHS compliant with RoHS 2.0(2015/863/EU)-amending

Pin Descriptions

Pin	Symbol	Name	Ref.
1	VeeT	Transmitter Ground (Common with Receiver Ground)	
2	TX Fault	Transmitter Fault.	1
3	TX1_Disable	Transmitter Disable of Ch1; Turns off transmitter laser output of Ch1.	
4	MOD_DEF(2)	2-wire Serial Interface Data Line (SDA).	
5	MOD_DEF(1)	2-wire Serial Interface Clock Line (SCL).	
6	TD2-	Inverted Transmit Data Input of Ch2.	
7	TD2+	Transmit Data Input of Ch2.	
8	LOS1	Loss of signal for Ch1.	
9	RD2+	Received Data Output of Ch2.	
10	RD2-	Inverted Received Data Output of Ch2.	
11	VeeT	Transmitter Ground.	
12	RD1-	Inverted Received Data Output of Ch1.	
13	RD1+	Received Data Output of Ch1.	
14	LOS2	Loss of signal for Ch2.	
15	VccR	Receiver Power Supply.	
16	VccT	Transmitter Power Supply.	
17	Tx2_Disable	Transmitter Disable of Ch2; Turns off transmitter laser output of Ch2.	
18	TD1+	Transmit Data Input of Ch1.	
19	TD1-	Inverted Transmit Data Input of Ch1.	
20	VeeT	Transmitter Ground .	

Notes:

1.TX_Fault is internally OR output for TX fault conditions in either Channel 1 or Channel 2.

In order to determine which channel is at fault, the Host can read the internal memory bits for

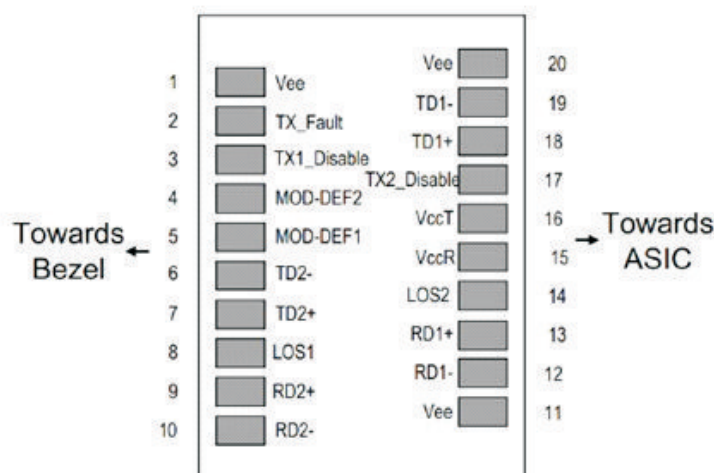

Pin-out of Connector Block on Host Board

Recommend Circuit Schematic

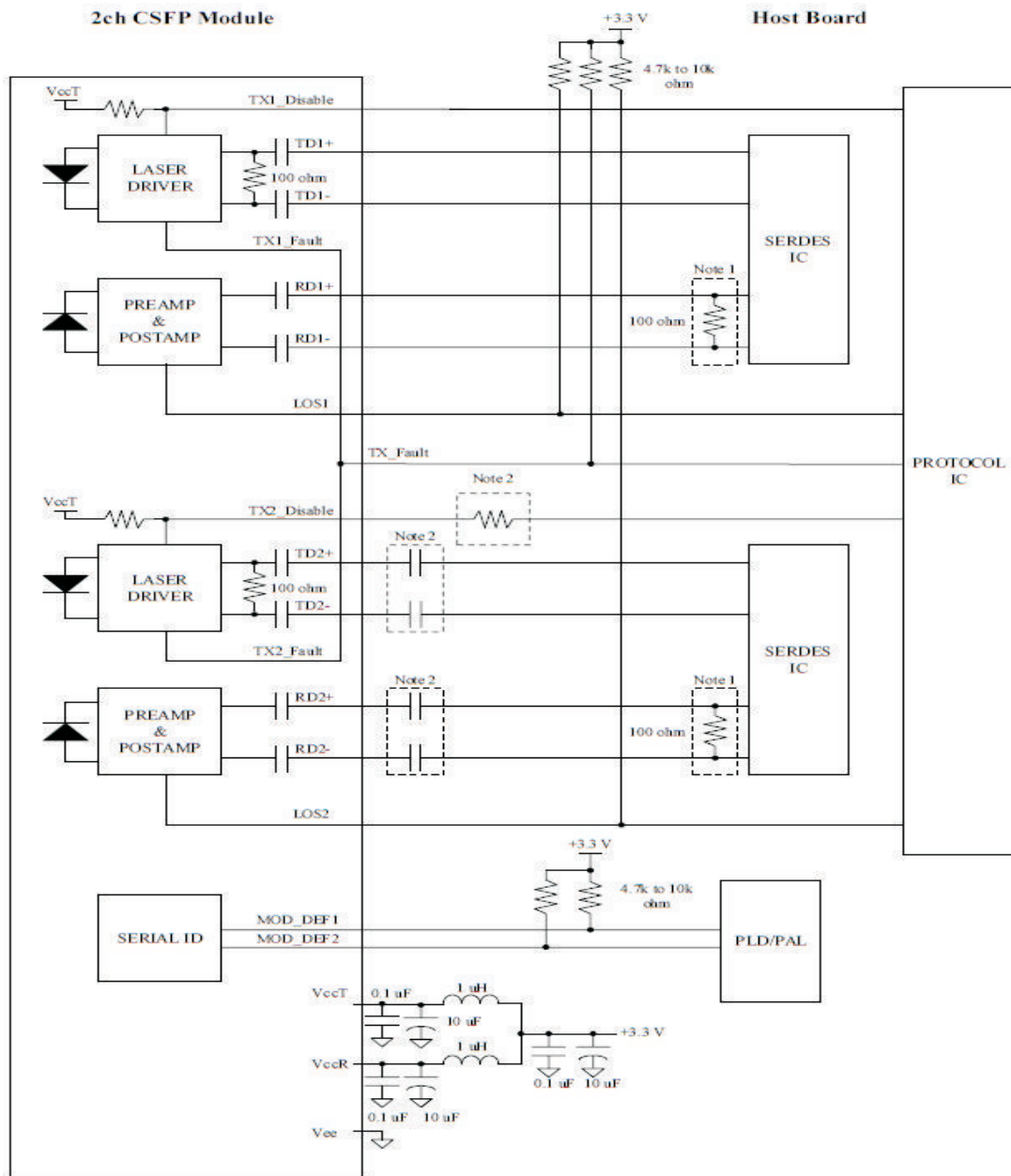

Absolute Maximum Ratings

Parameter	Symbol	Min	Typ	Max	Unit	Ref.
Maximum Supply Voltage	Vcc	-0.5		+4.0	V	
Storage Temperature	TS	-40		+85	°C	
Operating Humidity	RH	0		85	%	

Recommended Operating Conditions

Parameter	Symbol	Min	Typ	Max	Unit	Ref.
Power Supply Voltage	Vcc	3.13	3.30	3.47	V	
Power Supply Current	Icc			500	mA	
Case Operating Temperature	Tc	0		+70	°C	1
	Tl	-40		+85	°C	2
Data Rate(Gigabit Ethernet)			1.25		Gbps	
9/125um G.652 SMF	Lmax			20	km	

Notes:

- 1.For commercial class product.
- 2.For industrial class product.

Electrical Characteristics

Parameter	Symbol	Min	Typ	Max	Unit	Ref.
Transmitter						
Input differential impedance	Rin	-	100	-	Ω	1
Single ended data input swing	Vin, pp	250	-	1200	mV	
TX Disable-High	-	Vcc – 1.3	-	Vcc	V	
TX Disable-Low	-	Vee	-	Vee+ 0.8	V	
TX Fault-High	-	Vcc-0.5	-	Vcc	V	
TX Fault-Low	-	Vee	-	Vee+0.5	V	
Receiver						
Single ended data output swing	Vout, pp	300	400	800	mV	2
Data output rise time	tr	-	-	300	ps	3
Data output fall time	tf	-	-	300	ps	3
LOS-High	-	Vcc – 0.5	-	Vcc	V	
LOS-Low	-	Vee	-	Vee+0.5	V	

Notes:

1. AC coupled.
2. Into 100 ohm differential termination.
3. 20 – 80 %

Optical Characteristics

Parameter	Symbol	Min	Typ	Max	Unit	Ref.
Transmitter						
Output Opt. Power	PO	-9	-	-3	dBm	1
Optical Wavelength	λ	1260	1310	1360	nm	
Spectral Width (RMS)	$\Delta\lambda$	-	-	3	nm	
Optical Rise/Fall Time	tr/tf	-	-	260	ps	2
Total Jitter	TJ	-	-	0.35	UI	
Optical Extinction Ratio	ER	6	-	-	dB	
Receiver						
RX Sensitivity @1.25Gb/s	SENS	-	-	-22.5	dBm	3,4
Receiver Overload	-	-3	-	-	dBm	
Optical Center Wavelength	λ_C	1470	1490	1510	nm	
LOS De-Assert	LOSD	-	-	-25	dBm	
LOS Assert	LOSA	-40	-	-	dBm	
LOS Hysteresis	-	0.5	-	5	dB	

Notes:

- 1.Class 1 Laser Safety.
- 2.Unfiltered, 20-80%. Complies with Gigabit Ethernet eye masks when filtered.
- 3.Measured with conformance signals defined in FC-PI-2 Rev. 10.0 specifications.
- 4.Measured with PRBS 2-1⁷ at 10⁻¹² BER.

Mechanical Specifications

- ATOP's Small Form Factor Pluggable (SFP) transceivers are compatible with the dimensions defined by the SFP Multi-Sourcing Agreement (MSA), dimensions are in mm.

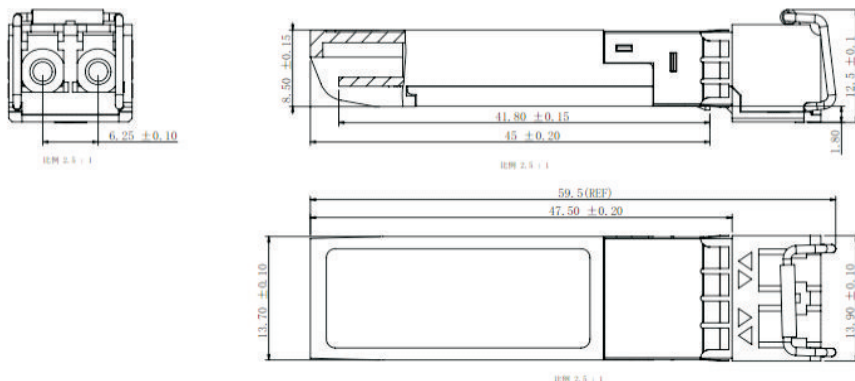

APCS34123xxL20

EEPROM Information

- Memory map for 2ch Compact SFP (option 2) is illustrated in below figure. A0h (1010000X) and B0h (1011000X) are the Serial ID addresses for channel 1 and channel 2, respectively. A2h (1010001X) and B2h (1011001X) are the Digital Diagnostic addresses for channel 1 and channel 2.

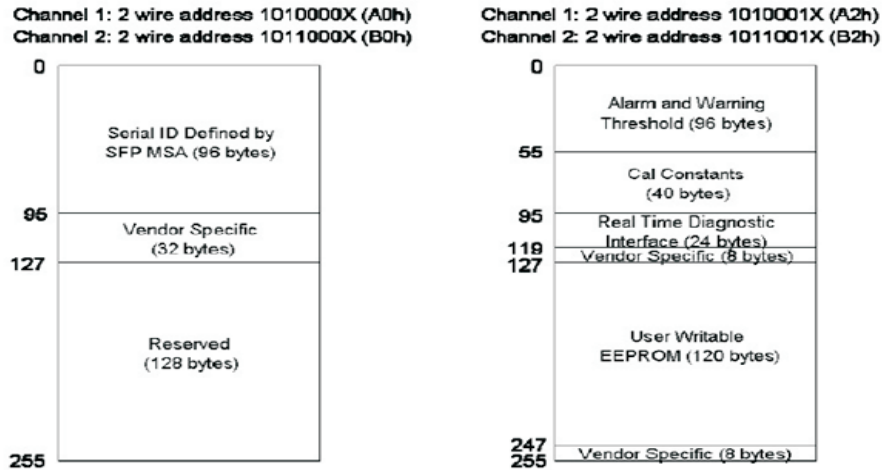

Digital Diagnostic Monitoring Interface

Five transceiver parameter values are monitored. The following table defines the monitored parameter's accuracy.

Parameter	Range	Accuracy	Calibration
Temperature	0 to +70°C (C)	±3°C	Internal
	-40 to +85°C (I)		
Voltage	2.97 to 3.63V	±3%	Internal
Bias Current	0 to 100mA	±10%	Internal
TX Power	-9 to -3dBm	±3dB	Internal
RX Power	-22.5 to -3dBm	±3dB	Internal

Revision History

Revision	Initiated	Reviewed	Approved	DCN	Release Date
Version1.0	Yangpeiyun	Sunbin	Dingzheng	New Released.	July 29, 2016
Version1.1	Tangzhiqiang	Yangpeiyun	Dingzheng	Update the new template	Dec 19, 2019



let's make it personal

atoptechnology.com