



40Gb/s QSFP+ Active Copper Cable

APCA04-QQCXXX-yy



40Gb/s QSFP+ Active Copper Cable

APCA04-QQCXXX-yy

Product Features

- ✓ Available in lengths of 1 to 7m
- ✓ 4 independent full-duplex channels up
- ✓ To 10.3Gbps data rate per wavelength
- Hot-pluggable QSFP +footprint
- ✓ RoHS compliant and Lead Free
- ✓ Power dissipation <1.5W (0~70°C)
- ✓ Commercial operating temperature optional
- ✓ Compliant with QSFP + MSA
- ✓ Fully comply with IEEE802.3ba and QDR specifications

Applications

- ✓ 40G Ethernet
- ✓ Infiniband 4X SDR DDR QDR
- ✓ Serial data transmission



Product Selection

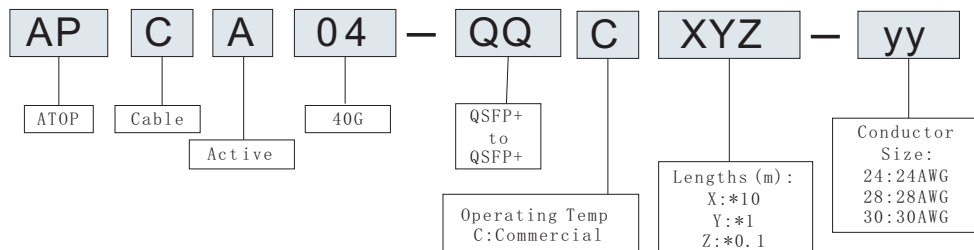

Part Number	Lengths	Wire Size
APCA04-QQC010-30	1m	AWG30
APCA04-QQC020-30	2m	AWG30
APCA04-QQC030-30	3m	AWG30
APCA04-QQC050-30	5m	AWG30
APCA04-QQC070-30	7m	AWG30
APCA04-QQC080-28	8m	AWG28
APCA04-QQC100-28	10m	AWG28

*For availability of additional cable lengths, please contact ATOP.

Pin Descriptions

Pin	Symbol	Name	Ref.
1	GND	Ground	
2	Tx2n	Transmitter Inverted Data Input, CML-I	
3	Tx2p	Transmitter Non-Inverted Data output, CML-I	
4	GND	Ground	
5	Tx4n	Transmitter Inverted Data Input, CML-I	
6	Tx4p	Transmitter Non-Inverted Data output, CML-I	
7	GND	GND	
8	ModSelL	The ModSelL is an input pin. When held low by the host, the module responds to 2-wire serial communication commands. The ModSelL allows the use of multiple QSFP+ modules on a single 2-wire interface bus. When the ModSelL is "High", the module shall not respond to or acknowledge any 2-wire interface communication from the host. ModSelL signal input node must be biased to the "High" state in the module	
9	ResetL	The ResetL pin must be pulled to Vcc in the QSFP+ module. A low level on the ResetL pin for longer than the minimum pulse length (t_Reset_init) initiates a complete module reset, returning all user module settings to their default state. Module Reset Assert Time (t_init) starts on the rising edge after the low level on the ResetL pin is released.	
10	VccRx	+ 3.3V Power Supply Receiver	
11	SCL	2-Wire Serial Interface Clock	
12	SDA	2-Wire Serial Interface Data	
13	GND	GND	
14	Rx3p	Receiver Non-Inverted Data Output, CML-O	
15	Rx3n	Receiver Inverted Data Output, CML-O	
16	GND	GND	
17	Rx1p	Receiver Non-Inverted Data Output, CML-O	
18	Rx1n	Receiver Inverted Data Output, CML-O	
19	GND	Ground	
20	GND	Ground	
21	Rx2n	Receiver Inverted Data Output, CML-O	
22	Rx2p	Receiver Non-Inverted Data Output, CML-O	
23	GND	Ground	
24	Rx4n	Receiver Inverted Data Output, CML-O	
25	Rx4p	Receiver Non-Inverted Data Output, CML-O	

26	GND	Ground
27	ModPrsL	Module Present, connect to GND
28	IntL	The IntL pin is an open collector output and must be pulled to host supply voltage on the host board. The INTL pin is de-asserted "High" after completion of reset, when byte 2 bit 0 (Data Not Ready) is read with a value of '0' and the flag field is read.
29	VccTx	+3.3 V Power Supply transmitter
30	Vcc1	+3.3 V Power Supply
31	LPMODE	The LPMODE pin shall be pulled up to Vcc in the QSFP+ module. This function is affected by the LPMODE pin and the combination of the Power_override and Power_set software control bits (Address A0h, byte 93 bits 0,1).
32	GND	Ground
33	Tx3p	Transmitter Non-Inverted Data Input, CML-I
34	Tx3n	Transmitter Inverted Data Output, CML-I
35	GND	Ground
36	Tx1p	Transmitter Non-Inverted Data Input, CML-I
37	Tx1n	Transmitter Inverted Data Output, CML-I
38	GND	Ground

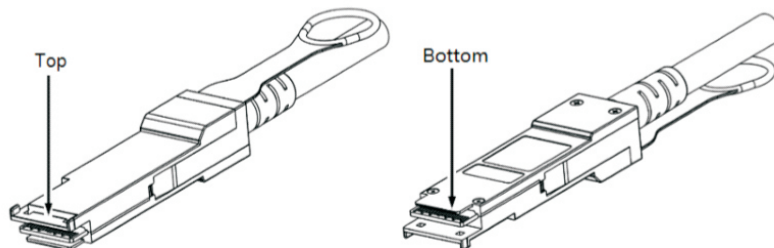
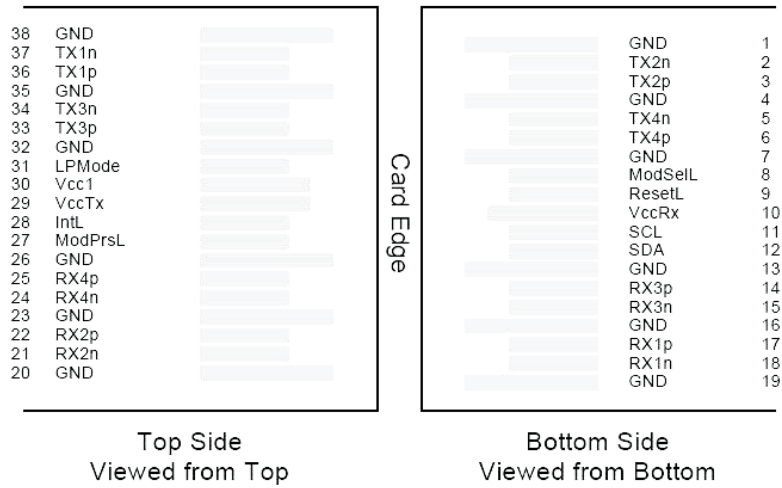

Pin-out of Connector Block on Host Board

Absolute Maximum Ratings

Parameter	Symbol	Min	Typ	Max	Unit	Ref.
Maximum Supply Voltage	Vcc	-0.5		+4.0	V	
Storage Temperature	TS	-4.0		+85	°C	
Operating Humidity	RH	0		85	%	

Recommended Operating Conditions

Parameter	Symbol	Min	Typ	Max	Unit	Ref.
Power Supply Voltage	Vcc	3.13	3.30	3.47	V	
Power Supply Current	Icc	-	-	1	A	Commercial
Case Operating Temperature	Tc	0	-	+70	°C	Commercial
Bit Rate Each Lane	Br	1	-	11.3	Gbps	
Length	Lmax	1	-	10	m	

Cable specifications

Parameter	Symbol	Min	Typ	Max	Unit	Ref.
Sizes	Rin	30		28	AWG	
impedance	Z	90	100	110	Ohm	

Product block diagram

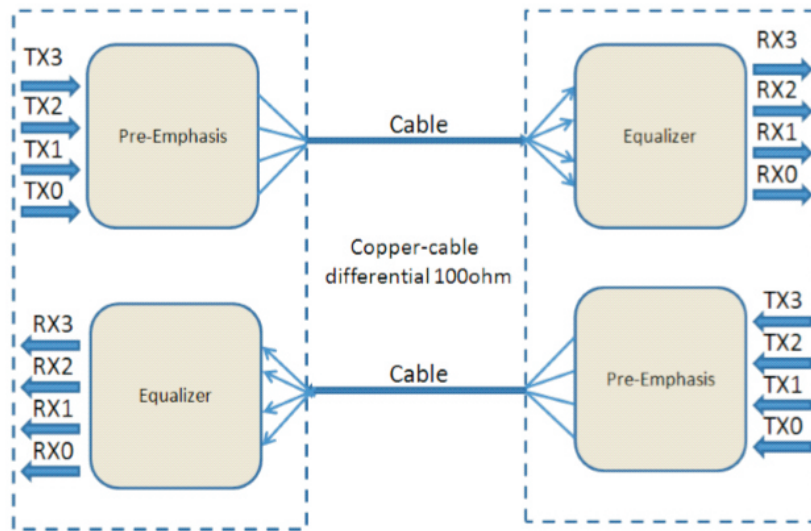

Mechanical Specifications

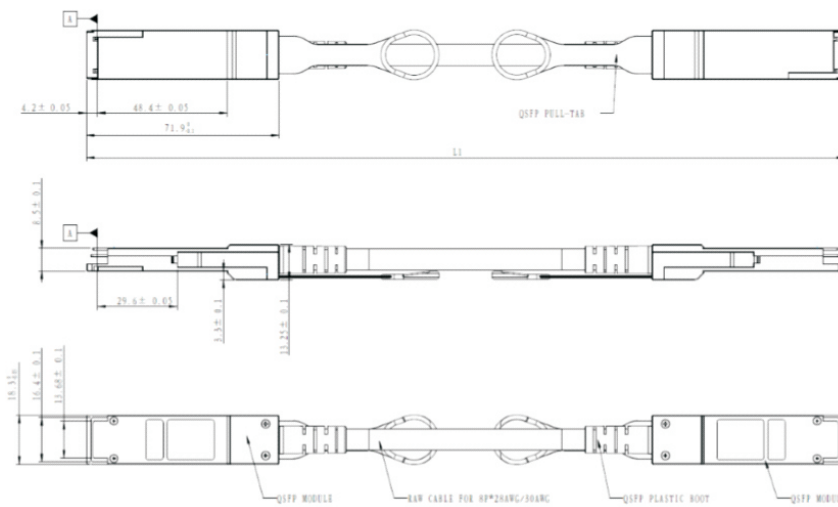

Unit: mm
Tolerance: ± 0.2mm

Revision History

Revision	Initiated	Reviewed	Approved	DCN	Release Date
Version1.0	Tang zhiqiang	Li Tao	Ding zheng	New Released.	Nov 22, 2019



let's make it personal

atoptechnology.com